

M76XL REQUIRES 4 HOLES IN THE SINK TOP. IF YOUR SINK DOES NOT HAVE 4 HOLES, YOU MUST CUT A 4th HOLE

A – Install 2 hose guides into holes as shown. Install with recess on top in center hole

B – Remove copper tube assembly from hose assembly.

C – Insert hose down through hose guide on right side and up through center hose guide.

D – Attach copper tube assembly onto hose and tighten securely. (This is a water seal)

E – Lower copper tube assembly into center hose guide, allowing copper tube & plastic tube to rest in recess in top of center hose guide.

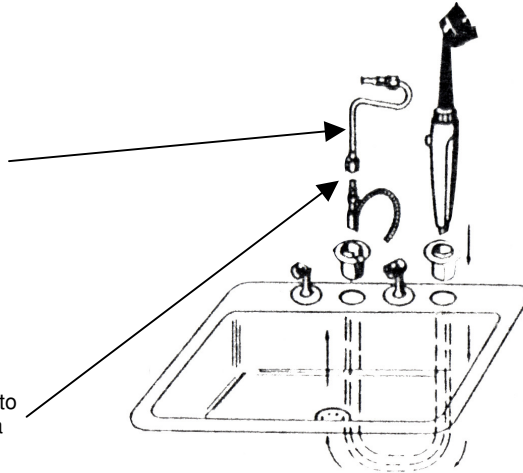

F – Follow steps 5 thru 7 of installation instructions and then come back to step G.

G – Attach copper tube assembly into right side of valve body center section and tighten securely. (This is a metal-to-metal water seal)

H – Attach one end of the clear plastic tube to detergent tank. Attach the other end to the hose assembly.

I – Follow steps 8 thru 11 of installation instructions to complete installation.

NOTE: Optional – Handle and brush assembly may either stand upright or lay on top of unit.